

Composite Building Cladding



- ❖ Wood Plastic Composite (WPC)
- ❖ Minimal Maintenance
- ❖ Easy to Install
- ❖ Eco-friendly
- ❖ Green Deal Potential



For commercial and residential cladding projects

DuraCladding

...designed for the future



ACCRUE CONSTRUCTION MATERIALS INC.

Industrial Marine Landscaping Architectural



Composite Cladding

DuraCladding is produced from Wood Plastic Composite (WPC) which is manufactured by an extrusion process using a mix of recycled plastics and hardwood with various bespoke additives. WPC is an immensely versatile material which combines the traditional appearance of timber

with the durability and resilience of an engineered composite.

DuraCladding is an ever increasingly popular choice for finishing the outside of commercial and domestic buildings. Otherwise known as weather-boarding or siding,

coloured or timber effect cladding is an attractive and economical way to finish the exterior of both new and refurbished buildings.

DuraCladding provides a hardwearing, protective layer against the elements and is an excellent insulator.

Project: Severn Trent Offices, Shelton, Shrewsbury
Client: Severn Trent, UK
Architect: Glenn Howells
Main Contractor: BAM Construction
Sub Contractor: Solaglas
Product: DuraCladding Type 150/21 Flush Charcoal

For the new Severn Trent offices in Shrewsbury, Glenn Howells specified Dura Cladding charcoal because of its sustainability credentials. DuraCladding is made from 87% recycled materials, comes with a warranty of up to 25 years and requires minimal maintenance which makes the life cycle costs much lower than natural wood. DuraCladding is also colour stable, giving the customer complete peace of mind that the cladding will retain its colour throughout its design life expectancy.

Eco-
Ideal for



friendly Cladding

new and refurbishment projects



UK Prime Minister David Cameron discussing eco-friendly cladding products with Dura Staff at UK Trade Show...



Project: Gerlach House, Kent
Client: Ashford Council UK
Product: DuraCladding Type
Flush 150/21 Charcoal

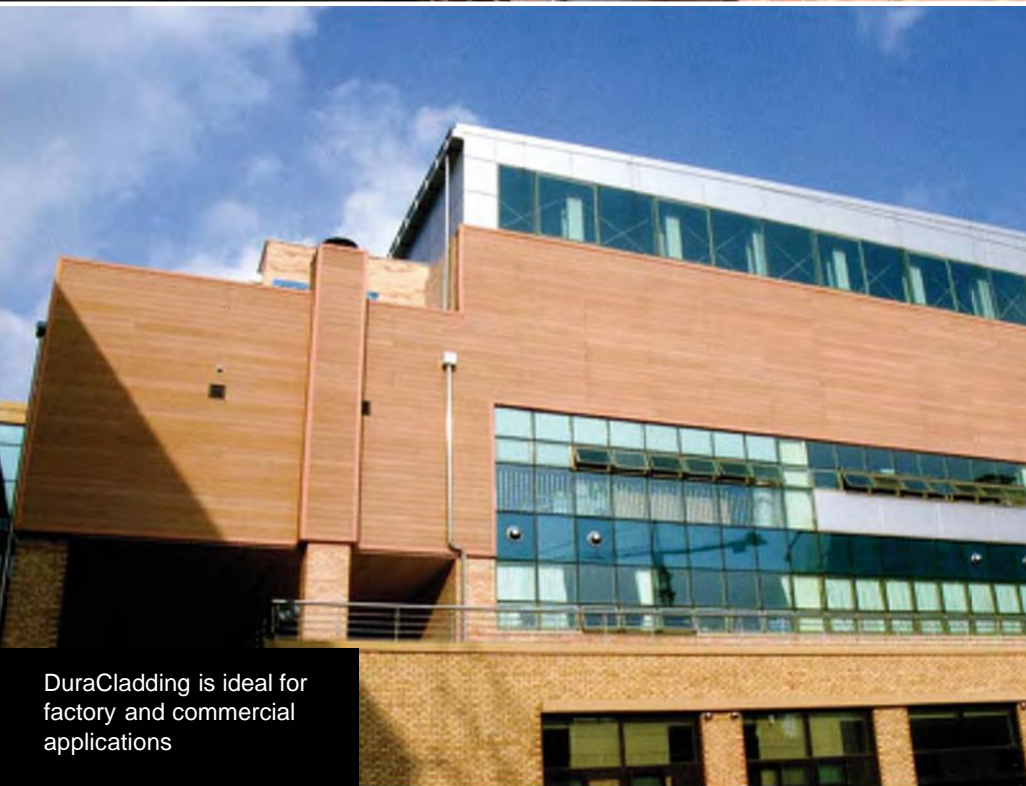

DuraCladding is ideal for factory and commercial applications

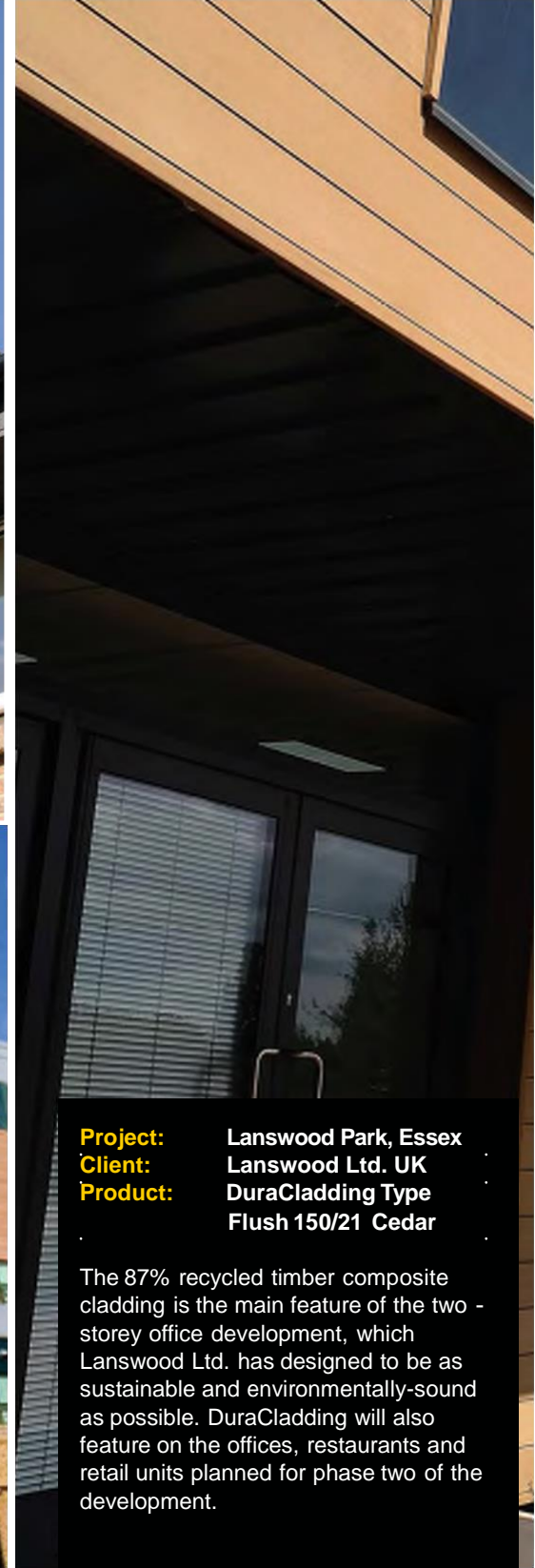

Project: Lanswood Park, Essex
Client: Lanswood Ltd. UK
Product: DuraCladding Type
Flush 150/21 Cedar

The 87% recycled timber composite cladding is the main feature of the two-storey office development, which Lanswood Ltd. has designed to be as sustainable and environmentally-sound as possible. DuraCladding will also feature on the offices, restaurants and retail units planned for phase two of the development.

Composite Cladding

DuraCladding

DuraCladding looks and feels like natural wood and its unique formula provides lightweight yet durable cladding that will not splinter, warp or rot throughout its 50 years design life expectancy.



Benefits



DuraCladding is made from 87% recycled materials and is also available as 100% FSC certified



Watch our You Tube video to see how quick and easy DuraCladding is to install



DuraCladding is UV Weather Tested to ISO 4892-2 Xenon Arc (5000hrs) to ensure it will not splinter, warp or rot and doesn't require any staining or painting



DuraCladding has a long life expectancy and requires minimal maintenance resulting in a lower life cycle cost when compared with traditional hard and softwood.

Composite Cladding

Transforms the exterior of any commercial or residential building

“Many people think that a timber composite product can’t be as ‘green’ as a natural wood product, but the truth is that our full range of timber composite products, including DuraCladding, meets the highest sustainability specifications and actually outperforms timber in service. It has a carbon footprint lower than wood and a significantly lower overall lifetime cost.”

S Burns, Director

The image shows a close-up, low-angle view of the exterior wall of the Edgebaston Tennis Club. The wall is covered in light grey, horizontally-oriented cladding panels. Large, three-dimensional, silver-colored letters are mounted on the wall, spelling out 'EDGEBASTON TENNIS CLUB' in two lines. The top line reads 'EDGEBASTON' and the bottom line reads 'TENNIS CLUB'. The letters are highly reflective and cast shadows on the wall. A small blue and white object is visible on the left side of the wall.

EDGEBASTON TENNIS CLUB

Project: Edgebaston Tennis Club
Contractor: Morgan Sindall
Sub Contractor: Hathaway Roofing Ltd.
Architect: Glenn Howells
Product: DuraCladding Type 150/21 Flush Light Grey

For the new tennis club at Edgebaston, Hathaway Roofing Ltd. wanted a bespoke light grey cladding and so DuraCladding was the obvious choice. Despite the natural variations used in DuraCladding, the company was able to work with the client to achieve a result that matched its specification. Thanks to the UV stability of DuraCladding, the client has complete peace of mind that the cladding will retain its colour throughout its fifty year life expectancy.

Louvre Cladding

An attractive & economical way to finish your building



Cladding benefits

- ▶ High performance composite construction
- ▶ High strength to weight ratio
- ▶ Permanent colour
- ▶ 316 stainless steel fixings available
- ▶ Low maintenance
- ▶ Easy to erect / install
- ▶ Corrosion and weather resistant
- ▶ Fire resistant grades available
- ▶ Simple cutting and installation on site
- ▶ Excellent value 'life cycle cost'
- ▶ UV Stable

Project: Social Housing, Lead Bitter Old Town Dock, Newport, UK
Architect: Powell Dobsons Architects
Product: Louvre Cladding Cedar

Louvre Cladding was specified by architects as a cost-efficient way of creating several feature walls on new social housing at Lead Bitter Old Town Dock. Louvre Cladding will transform the outside of any building and can be quickly and easily installed. It is also a great way to create a screen to hide any services on the exterior of the building.

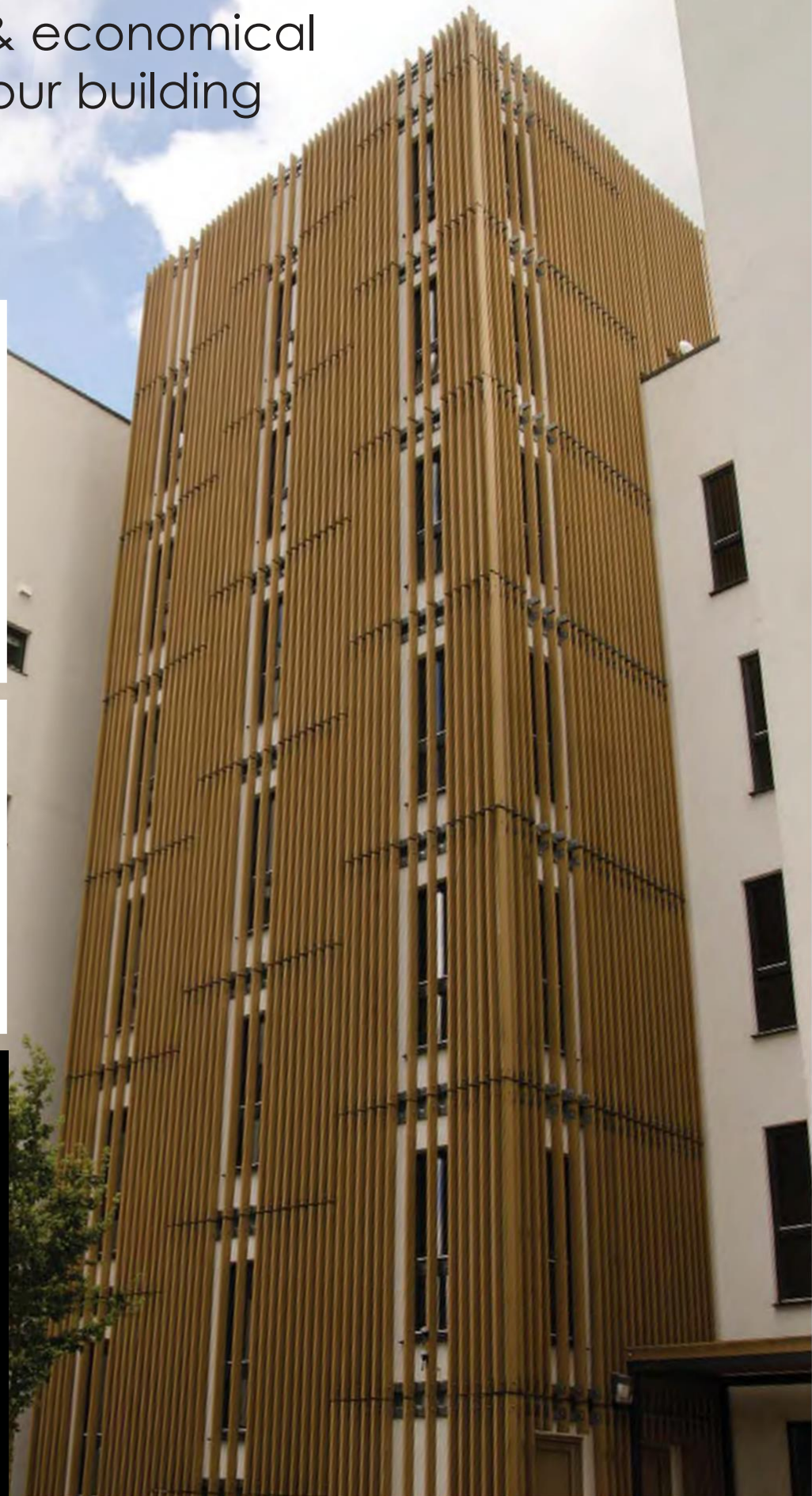



Louvre Cladding is used globally and its UV stability means that it will survive even the harshest climates.

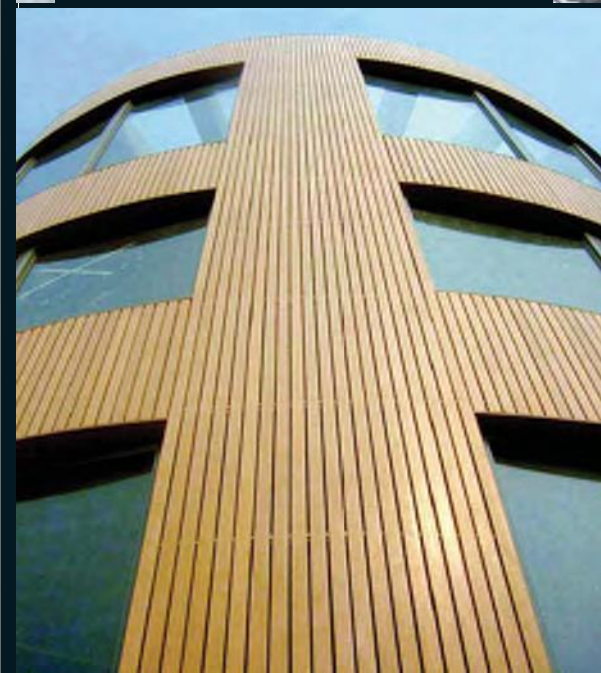

DuraCladding Weatherboard is suitable for the refurbishment of all traditional buildings...



Long-life weathering properties

DuraCladding benefits from a natural appearance. It also has the benefits of long life, light weight, low maintenance, non-rotting, corrosion and electrical resistance, low installation costs, long service life and is UV Stable.

DuraCladding products compete very favourably on a life cycle cost basis versus traditional materials due to their limited maintenance needs and long lifespan.

DuraCladding is designed and has been tested to withstand extreme weather conditions and temperature ranges.

Various standard cladding profiles are available, and custom profiles incorporating alternative fixing systems can be produced to specification.



Cladding Specifications

Wood Plastic Composite (WPC) Cladding for new or refurbishment projects

Type 150/21 Flush (Tongue & Groove)

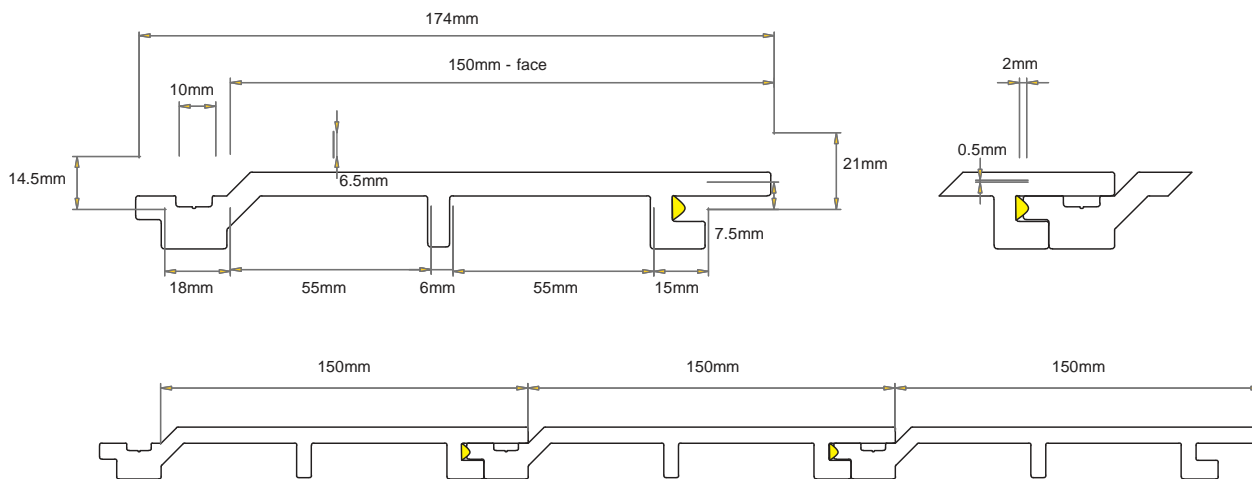

Type 150/21 Weatherboard (Tongue & Groove)

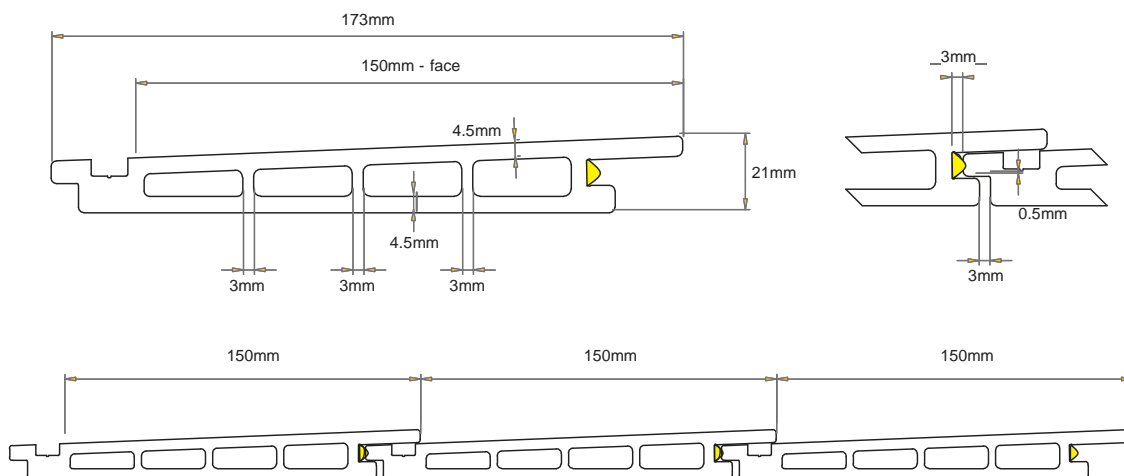

Type 194/21 Flush (Tongue & Groove) * Available to special order

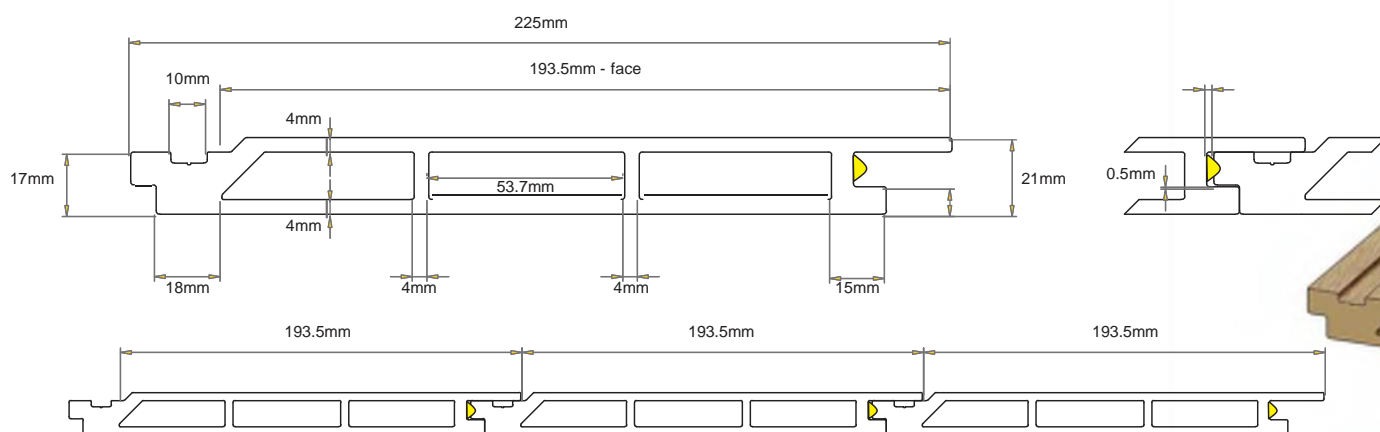

Louvre Cladding can be supplied in standard rectangular profiles to suit various cladding projects. Specific profiles can be produced to order.

Cladding Dimensions & Weights

Cladding Profile	Plank Thickness	Plank Length	Actual Plank Width	Maximum Fixing Span	Weight I/m
Type 150/21 Flush	21mm	4800mm	174mm	600mm	22kg
Type 150/21 Weatherboard	21mm	4800mm	173mm	600mm	TBA
Type 194/21 Flush	21mm	4800mm	225mm	600mm	TBA
Starter Trim	23mm	4800mm	60mm	600mm	4.8kg
Top Window Trim	38mm	4800mm	154mm	600mm	8.1kg
External/Internal/Expansion Trim	38mm	4800mm	139mm	600mm	13.2kg
Trim Insert	14mm	4800mm	28mm	600mm	0.24kg

Cladding Material Specifications

Characteristics	Unit	Test Reference
Tensile Strength	4.42mpa	BS 6399
Impact Strength	3.8kj	BS 6400
Flexural Strength	3.62gpa	ASTM D1037 - 93
Flexural Strength ****	TBC	ISO 4892-2
UV Aging Test	Pass	ISO 4892 - 2
Density	1.2g/cm ³	Ceram, Stoke on Trent
24 Hour Water Absorption	2.62%	ASTM D684
Flammability Resistance	Euro Class Bfl-S1	BS EN 13501-1 (TBC)
Fire Resistance	Pass	476 Part 7 Class 3
Expansion Rate	6.51 x 10-5K	Ceram, Stoke on Trent
Weatherability	No Damage at 100 cycles	MOAT 22
Thermal Conductivity	0.154 W/m.K.	Indicative result
Frost Resistance	No Damage	DD CEN/TS 772-22 :2006
Maximum Thermal Expansion Rate*	0.038mm/min/°change	ESG Report M5703R1 Rev1
Maximum Thermal Contraction Rate**	0.036mm/min/°change	ESG Report M5703R1 Rev1
Structural Wind Load-Negative	<654.86kg***	ESG Report M5703R1 Rev1
Structural Wind Load-Positive	<2308.6kg	ESG Report M5703R1 Rev1

*from 60 to 80°C **from 70 to 30°C ***Dura Cladding exceeded the test rig capacity ****After UV aging (1000 hours & rain)

Cladding Trims and Accessories



Starter Trim



Top Window Trim



End Caps and Plugs



Trim Insert



External/Internal/
Expansion Trim

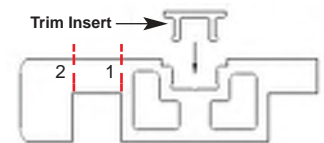

Red lines indicate cut lines
1 - Cut line 1 for internal corners
2 - Cut line 2 to make expansion trim

Cladding Colour Options

Colours shown are representative only, actual colours may vary slightly. Colour samples available on request. For large orders, bespoke colours can be selected.

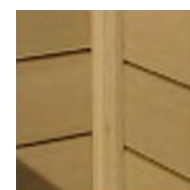

CEDAR

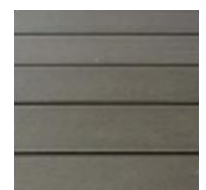

CHARCOAL

The Green Deal

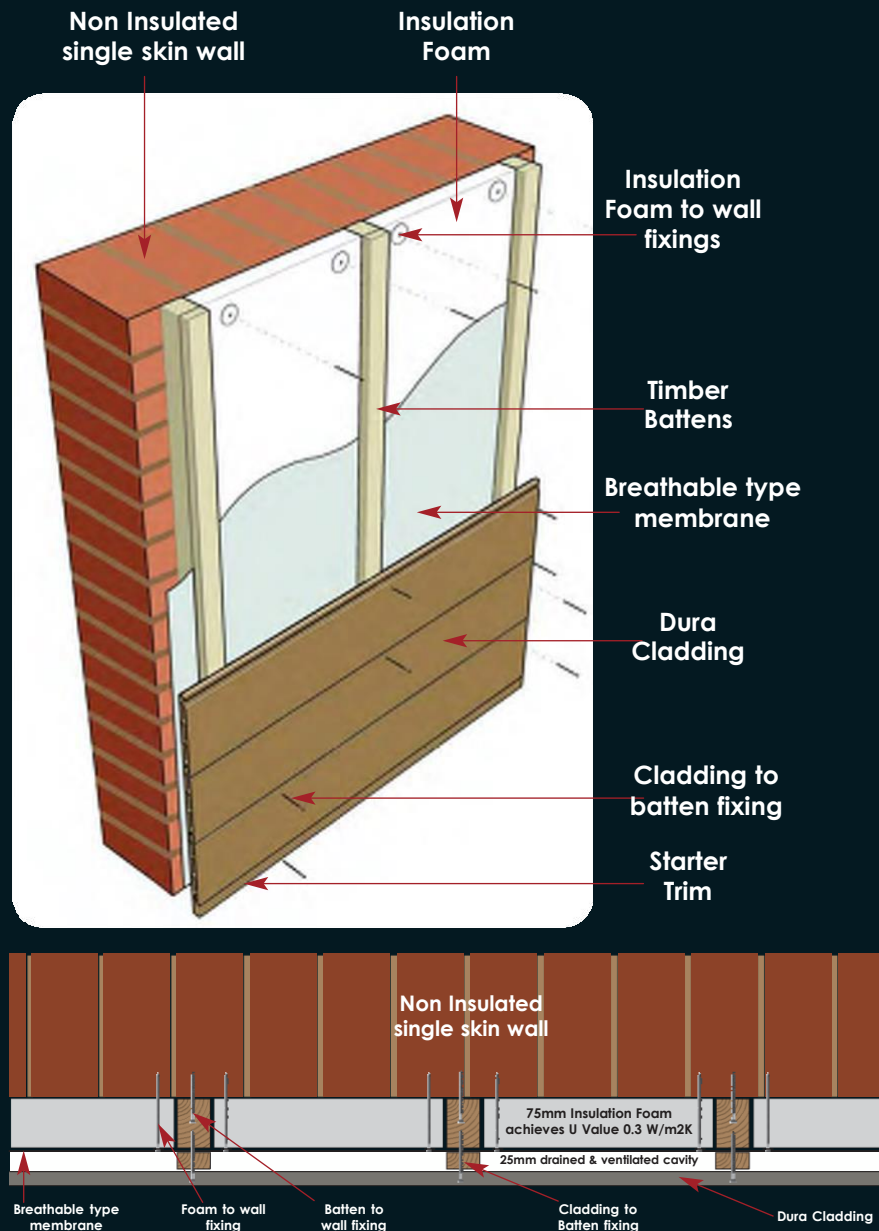

Installation system

DuraCladding is generally installed onto 50mm x 50mm timber battens screwed to the wall and spaced at 400mm centres.

When insulating exterior walls, the battens need to be increased in depth to 100mm.

75mm thickness Celotex FR5000 insulation or similar is then fixed to the wall between the battens, leaving a 25mm air gap at the front. DuraCladding is then fixed to the timber batten with screws in the usual way. This insulating system benefits houses, barns, outbuildings, offices, factories and commercial buildings, providing vastly improved insulation, as well as transforming the appearance.

OUR REGIONAL OFFICES:

UK (Head Office)

ACM International Inc.

Auckland Hill,
West Norwood, SE27,
London, UK.

Contact: Andy Lee - GGM
Office: + 44 75 535 83910
Andyacrue@gmail.com
andyveeaml@gmail.com

USA / Canada

AMP [USA]

9 Pinewood Lane,
Warren, New Jersey,
07059, USA.

Contact: Lisa Vega
Office +1 917 750 5758
lisa Vega@gmail.com
John Ross
Office: + 173274 27179
johnrossaml@gmail.com

Balkans Region

ACM [Albania]

Tirana Sheraton Hotel
Shopping Mall, Zyra G2
Tirana, Albania.

Contact: Petro Vjero
Int'l: +355 423 79670
Mobil: 069 5430 943
Petrovjeroaml@gmail.com

Israel

ACM [Israel]

2/2 Zeev Sharf St,
Jerusalem,
97842. Israel.

Contact: Jacob / Bary
Int Tel: +972 54 907 770
jacobariaml@gmail.com



Due to our policy of continual improvement we reserve the right to change specifications at all times without prior notice.



ACCURUE CONSTRUCTION
MATERIALS INC

